

DEPARTMENT OF THE ARMY TECHNICAL BULLETIN

**CALIBRATION PROCEDURE FOR
INDICATOR, RESISTANCE, INHALATION
AND EXHALATION, Q213
NSN 6680-01-016-2665**

Headquarters, Department of the Army, Washington, D. C.
24 June 1977

REPORTING OF ERRORS

You can help improve this publication by calling attention to errors and by recommending improvements and stating your reasons for the recommendations. Your letter or DA Form 2028, Recommended Changes to Publications and Blank Forms should be mailed directly to Commander, US Army Armament Materiel Readiness Command, Attn: DRSAR-MAS-C, Aberdeen Proving Ground, MD 21010.

	Paragraph	Page
SECTION I. IDENTIFICATION AND DESCRIPTION		
Test instrument identification	1	1
Calibration data card (DA Form 2416).....	2	1
Calibration description.....	3	1
II. EQUIPMENT REQUIREMENTS		
Equipment required.....	4	2
Accessories required.....	5	2
III. CALIBRATION PROCESS		
Preliminary instructions.....	6	3
Equipment setup	7	3
AIR FLOW gage	8	4
RESISTANCE gage	9	5
Final procedure.....	10	6

**SECTION I
IDENTIFICATION AND DESCRIPTION**

1. Test Instrument Identification. This bulletin provides instructions for the calibration of Indicator, Resistance, Inhalation and Exhalation, Q213. The inhalation and exhalation resistance indicator will be referred to as the "TI" or test equipment throughout this bulletin.

a. *Model Variations.* None.

b. *Time and Technique.* The time required for this calibration is approximately 2 hours, using the physical technique.

2. Calibration Data Card, (DA Form 2416). Forms, records, and reports required for calibration personnel

at all levels are prescribed by TM 38-750. DA Form 2416 must be annotated in accordance with TM 38-750 for each calibration performed.

3. Calibration Description. TI parameters and performance specifications which pertain to this calibration are listed in table 1.

Table 1. Calibration Description

Test Instrument Parameters	Performance Specifications
Pressure	Range: 0 to 10 centimeters of water Accuracy: \pm 2% of full scale
Airflow	Range: 0 to 90 liters/minute Accuracy: \pm 2% of full scale

**SECTION II
EQUIPMENT REQUIREMENTS**

4. Equipment Required. Table 2 identifies the specific equipment used in this calibration. The equipment is issued with secondary transfer standards calibration set, NSN 6695-00-621-7877. Alternate items may be used by the calibrating activity when the equipment listed in table 2 is not available. The items selected must be verified to perform satisfactorily prior to use and must bear evidence of current calibration. The equipment must meet or exceed the minimum use specifications listed in table 2. The accuracies listed in

table 2 provide a four-to-one accuracy ratio between the standard and TI. When the four-to-one ratio cannot be met, the actual accuracy of the equipment selected is shown in parenthesis.

5. Accessories Required. Some of the accessories listed in table 3 are issued as indicated in paragraph 4 above, except for the one which is fabricated as shown in figure 1. All are to be used in this calibration procedure. When necessary, the items other than the one fabricated may be substituted by equivalent items.

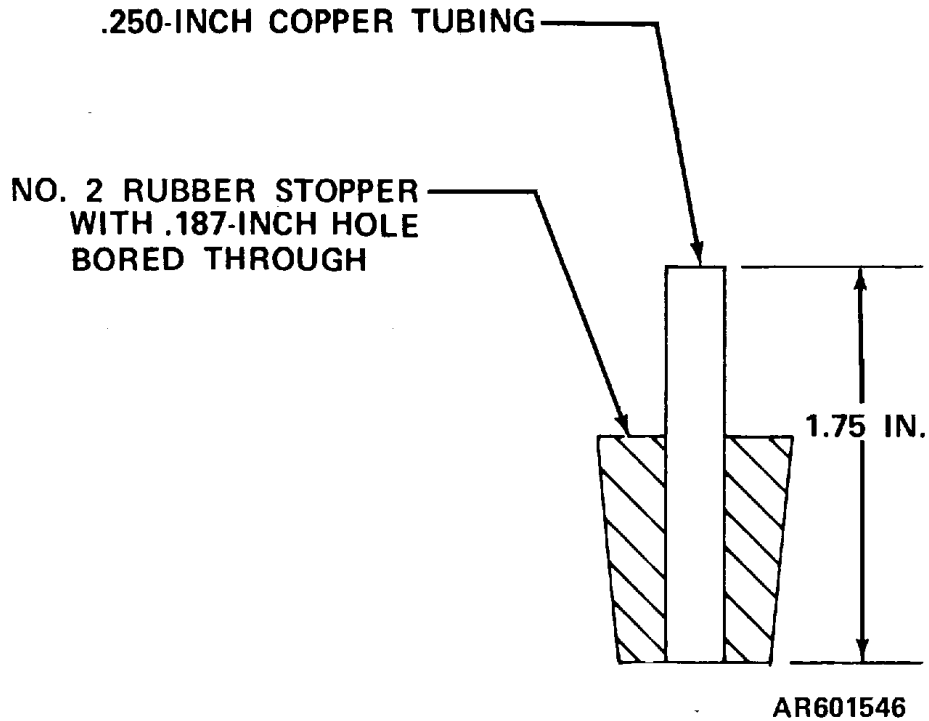

Figure 1. Fabrication instructions for connector (B1).

Table 2. Minimum Specifications of Equipment Required

Item	Common Name	Minimum Use Specifications	Manufacturer, Model, and Part Number
A1	FLOWMETER *	Range: 3.5 cu ft/min Accuracy: $\pm 0.5\%$ of reading ($\pm 2\%$ of full scale)	Shutte and Koerting, Model 18200 Series (7920950) Tube - H-CFB Float - 4-BP-1
A2	MANOMETER	Range: 0 to 4 in. of water Accuracy: $\pm 0.5\%$	Wallace and Tiernan, Model 65D-4C-0120X or FA145600 (7912573)

*Procedure limitations: Accuracy $\pm 2\%$ of full scale.

Table 3. Accessories Required

Item	Common Name	Description and Part Number
B1	CONNECTOR *	Fabricate in accordance with figure 1.
B2	TUBING	Plastic, 1/4-inch (R3603F). Length as required.
B3	TEE	Connector, elastic tubing, branded, 3/8-inch ID, 1/4-inch to 1/2-inch OD (7909927).
B4	NITROGEN CYLINDER	Nitrogen, technical w/cyl, oil free (7910373).
B5	REGULATOR	Regulator, water pumped nitrogen (MIS10325TYPE2)
B6	VALVE	Needle valve, 1/8-inch NPT female, inlet and outlet; ROSKA 2001.

* Also used to calibrate the following equipment:

- Tester, Air Leakage (Dry Bubble), Q204 (TB 3-6665-313-50)
- Tester, Leakage, Valve Assembly, Q210 (TB 3-6665-314-50)

SECTION III CALIBRATION PROCESS

NOTE

Unless otherwise specified, verify the results of each test and take corrective action whenever the test requirement is not met before continuing with the calibration.

6. Preliminary Instructions. *a.* The instructions outlined in this section are preparatory to the calibration process. Personnel should become familiar with the entire bulletin before beginning the calibration.

b. Items of equipment used in this procedure are referenced within the text by common name and item identification number as listed in tables 2 and 3. For the identification of equipment referenced by item numbers

prefixed with A, see table 2, and for prefix B, see table 3.

7. Equipment Setup. (fig. 2). *a.* Adjust the mechanical zero-adjustment on TI resistance gage to zero.

- b.* Set the POWER switch to OFF.
- c.* Set INHALE-EXHALE switch to center off position.
- d.* Set SEAL switch to OFF.
- e.* Turn AIRFLOW VALVE fully counterclockwise.
- f.* Connect power cable connector to 115-volt, 60 Hz receptacle.
- g.* Set POWER switch to ON. Pump should operate.
- h.* Allow TI to operate for at least 10 minutes.

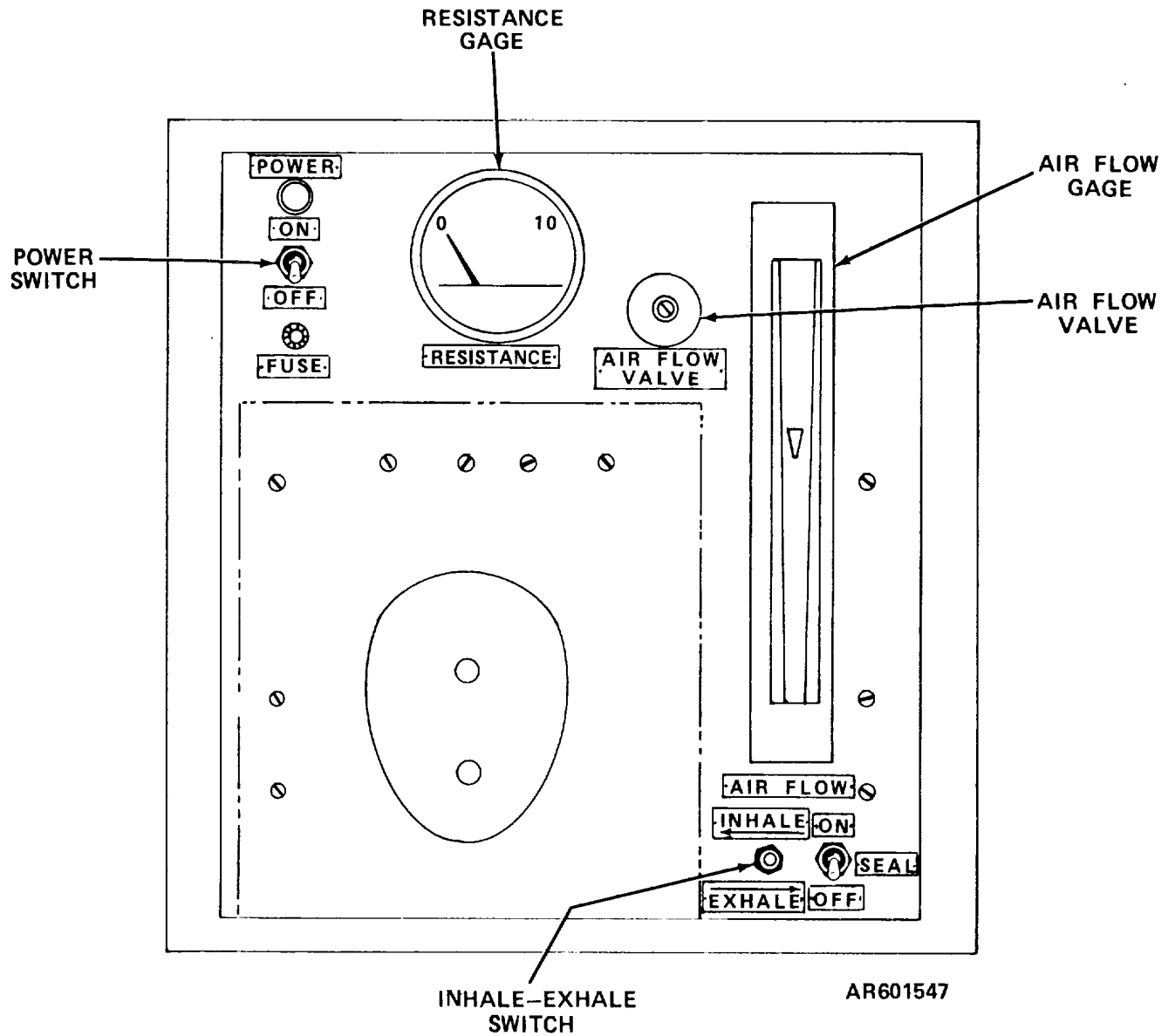

Figure 2. Location of TI controls and instruments used during calibration.

8. AIR FLOW Gage. a. Performance Check.

(1) Connect the test equipment as shown in figure 3.

(2) Set and hold the INHALE-EXHALE switch to EXHALE.

(3) Adjust the AIR FLOW VALVE until the AIR FLOW gage (fig. 2) indicates 85. The flowmeter (A1) must indicate between 225 and 235.

(4) Release the INHALE-EXHALE switch.

b. Adjustments. No adjustments can be made.

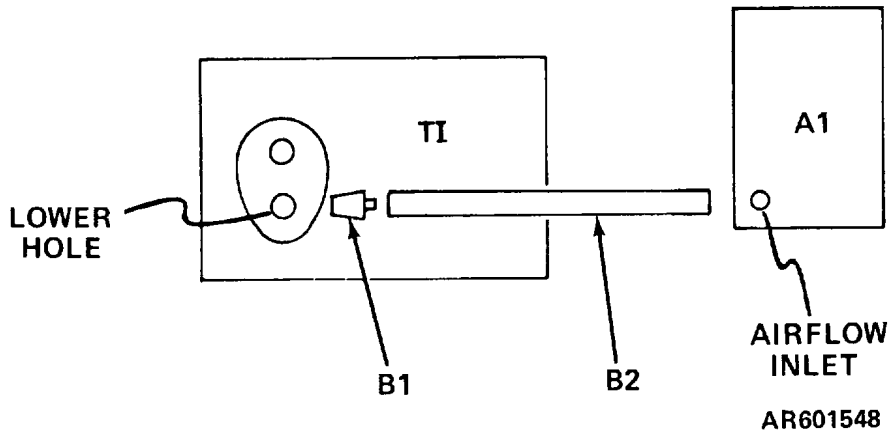

Figure 3. AIR FLOW gage performance check, equipment setup.

9. RESISTANCE Gage. a. Performance Check.

- (1) Connect the test equipment as shown in figure 4.
- (2) Close valve (B6).
- (3) Adjust the valve on the nitrogen cylinder (B4) and regulator (B5) until the RESISTANCE gage pointer indicates "2" on the scale. The manometer (A2) must indicate as shown in table 4.
- (4) Repeat (3) above for each major division on the RESISTANCE gage scale.

CAUTION

Since a sudden change in pressure could damage the TI, do not disconnect the equipment before returning the TI to atmospheric pressure.

(5) After the performance check is completed, close the valve on the nitrogen cylinder (4) and slowly open valve (B6) to return the system to atmospheric pressure.

(6) Disconnect the test equipment.

b. Adjustment. No adjustments can be made.

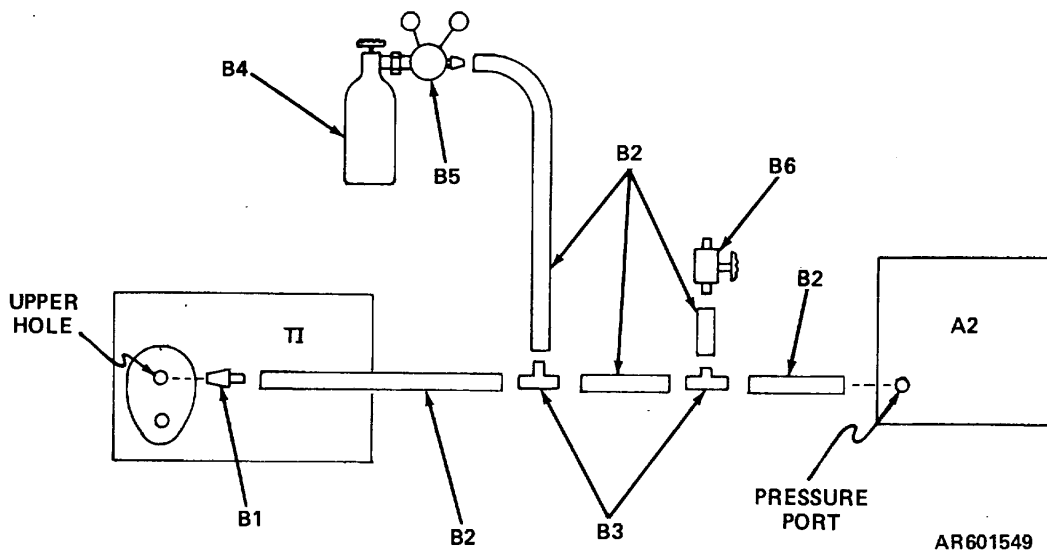

Figure 4. Resistance gage performance check, equipment setup.

Table 4. RESISTANCE Gage Performance Limits

Scale Major Division Indication (Centimeters of Water)	Acceptable Manometer Indications (Inches of water)	
	Min.	Max.
2	0.709	0.866
4	1.496	1.653
6	2.283	2.441
8	3.071	3.228
10	3.858	4.016

10. Final Procedure. a. Deenergize and disconnect all equipment.

b. In accordance with TM 38-750, annotate and affix DA Label 80 (US Army Calibration System). When

the TI does not indicate within the limits specified in paragraph 8a or in table 4, annotate the affix DA Form 2417 (Unserviceable or Limited Use) tag.

By Order of the Secretary of the Army:

Official:

PAUL T. SMITH
Major General, United States Army
The Adjutant General

BERNARD W. ROGERS
General, United States Army
Chief of Staff

DISTRIBUTION:

To be distributed in accordance with DA Form 12-34A requirements for Calibration Procedures Publications.

U.S. GOVERNMENT PRINTING OFFICE: 1977-765010/530

RECOMMENDED CHANGES TO EQUIPMENT TECHNICAL PUBLICATIONS



THEN... JOT DOWN THE DOPE ABOUT IT ON THIS FORM, CAREFULLY TEAR IT OUT, FOLD IT AND DROP IT IN THE MAIL!

SOMETHING WRONG WITH THIS PUBLICATION?

FROM: (PRINT YOUR UNIT'S COMPLETE ADDRESS)

DATE SENT

PUBLICATION NUMBER

PUBLICATION DATE

PUBLICATION TITLE

BE EXACT... PIN-POINT WHERE IT IS

PAGE NO.

PARA-GRAPH

FIGURE NO.

TABLE NO.

IN THIS SPACE TELL WHAT IS WRONG AND WHAT SHOULD BE DONE ABOUT IT:

TEAR ALONG PERFORATED LINE

PRINTED NAME, GRADE OR TITLE, AND TELEPHONE NUMBER

SIGN HERE:

DA FORM 2028-2
1 JUL 79

PREVIOUS EDITIONS ARE OBSOLETE.

P.S.—IF YOUR OUTFIT WANTS TO KNOW ABOUT YOUR RECOMMENDATION MAKE A CARBON COPY OF THIS AND GIVE IT TO YOUR HEADQUARTERS.

